

# DEVELOPMENT OF A WIRELESS SIGNAL ACQUISITION SYSTEM FROM SENSORS FOR COMFORT AND ENERGY QUALITY

***Israel Zamudio Ramírez***

Universidad Autónoma de Querétaro  
*izamudio13@alumnos.uaq.mx*

***Arturo Yosimar Jaen Cuellar***

Universidad Autónoma de Querétaro  
*ayjaen@hspdigital.org*

***Roque Alfredo Osornio Ríos***

Universidad Autónoma de Querétaro  
*raosornio@hspdigital.org*

## **Resumen**

La adquisición de señales inalámbricas de sensores representa una variedad de ventajas sobre los sistemas de comunicación por cable. Este trabajo presenta un sistema de adquisición de señales basado en antenas ZigBee que aprovecha sus características para hacer un sistema flexible que puede ser utilizado en diferentes campos sin el uso necesario de una PC ya que se utiliza una pantalla táctil y un microcontrolador. El sistema es implementado en un edificio para monitorear todas las variables físicas que se refieren a la comodidad de las personas, tales como luminosidad, temperatura, humedad, concentración de gas, humo, presencia humana, rotura de vidrios, entre otros. La medición de estas variables también es utilizada para activar algunas funciones extras del sistema, por ejemplo, alarmas en caso de presencia de fuego. El sistema almacena información de todos los sensores de toda la red creada en una Micro SD y crea gráficos históricos de dichas variables, además, es posible visualizar lecturas en tiempo real.

**Palabras claves:** Pantalla táctil, red de sensores inalámbrica, ZigBee.

## **Abstract**

*The acquisition of wireless signals from sensors represents a variety of advantages over cable communication systems. This work presents a ZigBee-based signal acquisition system that takes advantage of its features to make a flexible system that can be used in different fields without the necessary use of a PC since a touchscreen and a microcontroller is used. The system is implemented in a building to monitor all the physical variables that are referred for the comfort of people, such as luminosity, temperature, humidity, gas concentration, smoke, human presence, glass breakage among others. The measure of these variables also could contribute to define or activate some extra-functions of the system, for example, alarms in case of fire presence. The system stores information of all sensors of all the network created in a Micro SD and uses it to make plots, also it is possible to visualize real-time readings.*

**Keywords:** *Touchscreen, wireless sensor network (WSN), ZigBee.*

## **1. Introduction**

In recent years, the introduction of network-enabled devices into the home environment has increased at an unprecedented rate [Bromley, 2003]. Home automation has taken the advantage of network-enabled devices. According to [Stavropoulos et al., 2010], home automation requires the introduction of technology within the home to enhance the quality of life of its occupants. In this area, there are three basic characteristics that need to be addressed: comfort, efficiency, and safety [Khusvinder et al., 2009]. Nowadays, several devices can be found to automate homes and buildings to monitor several physical variables all the time by using wired or wireless networks. Wired networks costs are lower; however, the drawbacks in the installation usually make it the second option [Semanur et al., 2016]. Moreover, wireless technologies such as Wi-Fi, Bluetooth, ZigBee have the potential for the remote control and monitoring of variables used in automation of buildings. It would be very helpful to use low power consumption devices for the automation of buildings.

Several works have been developed to automate buildings such as in [Dobrescu, 2014] where a domotic embedded system for room temperature monitoring is developed with the help of a central PC and a microcontroller. Others like [Eurico et al., 2014], [Brito et al., 2014], [Cofré et al., 2012], [Vikram, 2016] implement automation systems using wireless technologies which add a degree of simplicity when installing due to a decrease in the number of wires, but such works have in common a lower system integration, an important fact when there is a necessity to expand the number of variables to detect and the number of rooms to be automated. Furthermore, to make a more flexible system it is necessary to store, plot and manage a big amount of data without utilizing a PC in the field. Besides, these systems are capable of being used in different applications making them very robust, configurable and flexible.

In this paper, a wireless building automation system is described. The proposed system can integrate new nodes to the current network according to personal necessities by updating them with the help of a software wizard developed on purpose for this task. Another feature of the proposed system is that it allows easy addition and removal of sensors with the help of Plug-and-Use sockets, making a more flexible system capable of being used with a wide variety of sensors that can be spread around different places to, in this way, take their samples at the same time and show them in the form of plots or real-time readings. The system has the power to save big amounts of data which makes it suitable for different uses and applications. Additionally, it allows the monitoring of electrical sensors by using ZigBee antennas and a microcontroller Arduino Due with a touchscreen module. The sensors can monitor information of different physical magnitudes such as temperature, luminosity, presence, gas concentration, glass breakage, among others, in order to establish a clear state of the building in real time. The wireless home network is implemented with wireless ZigBee Routers and End Devices modules that communicate centrally with a ZigBee coordinator. The proposed system is validated by implementing it in a building located in the Universidad Autónoma de Querétaro during two months. After this period of tests, it will be implemented in a building named Academic Center of Advanced and Sustainable

Technologies (CATAS for its acronym in Spanish) which is under construction at this time. The obtained results demonstrate that this system can resist environmental conditions (into a building), and it works pretty well during long periods of time giving accurate records of every variable measured indicating the functionality and efficiency of the system.

## 2. Methods

According to [Sánchez, 2004], domotic refers to a home automated or commonly called intelligent house, which is a house whose elements and devices are integrated and automated with the help of a network. Generally, a domotic system will dispose of a communication network that permits the interconnection of some equipment (detectors and sensors) in order to get all the information of a domestic environment and then, with the help of a smart central unit, process the information [O'Driscoll, 2000], as shown in figure 1.

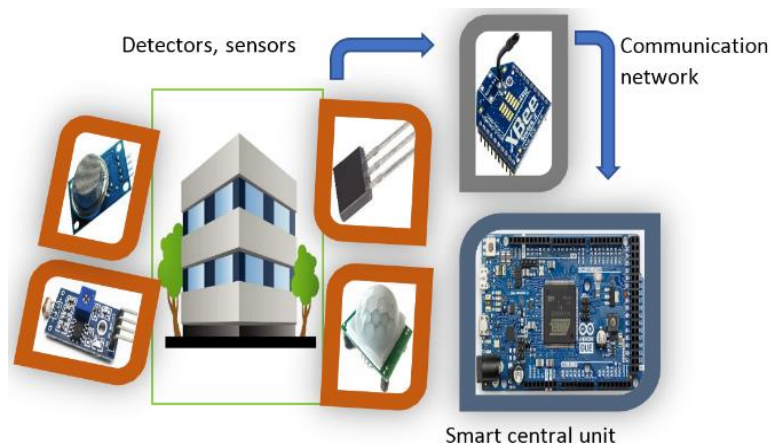

Figure 1 Home automation and its requirements.

Smart home grids are installed using wired or wireless networks. Although wireless network costs are higher, they are easier to install. There are many wireless technologies found in the market, but the most common are free licensed like ZigBee, Bluetooth, and Wi-Fi. The cost, power consumption, and performance are the main selection criteria for wireless network nodes. The main features of these technologies are shown in table 1.

Table 1 Main characteristics of free license wireless technologies.

<b>Technology</b>	<b>Data Rate</b>	<b>Max power consumption</b>	<b>Typical range</b>
ZigBee	20 to 250 kbps	3 mW	10-100 m
Bluetooth	1 to 3 Mbps	100 mW	2-10 m
IEEE 802.11b	1 to 11 Mbps	100 mW	30-100 m

Bluetooth technology has a low range and, from a scalability point of view, there is a strict limitation in the number of home equipment attachable to the Bluetooth master device due to the characteristics of the protocol. Although Wi-Fi has high range and big data rate, the ZigBee technology offers lower power consumption, which is an important aspect of home automation.

The interference problems between the possible standards have been investigated. For example, [Shuaib et al., 2006] researched the coexistence of ZigBee, Bluetooth, and Wi-Fi. The three protocols use the same 2.4 GHz ISM band. It can be concluded that ZigBee and Wi-Fi can exist together with fewer interference problems than alternative technologies currently available

ZigBee defines a set of protocols based on IEEE 802.15.4 standard and it uses three main types of devices to implement its architecture [Maxim, 2008], as illustrated in figure 2.

- ZigBee Coordinator (ZC). The most complete and important device, its function is to store data and it is the coordinator of the network.
- ZigBee Router (ZR). Its main function is to interconnect devices separated and limited due to its range in the network.
- ZigBee End Device (ZED). This device can maintain communication with its father node (the node that gave it the access to the network) a ZC or a ZR but not to other devices. In this way, this node can be sleeping most of the time and have lower power consumption rates.

Due to a lesser range among the nodes, frequently a packet must be sent repeatedly with the use of routers to increase the scope (a good feature of ZigBee), furthermore, ZigBee can send the information in two modes, API (Application Programming Interface) and AT (Application Transparent). Although AT mode

(data is not created from the XBee) is simpler than API, it cannot be easily implemented in a network because its main use is to send information between two devices. On the other hand, API mode is more complex but sends all the information created from the XBee in one packet, as shown in figure 3.

Note: MSB= most significant byte, LSB= less significant byte.

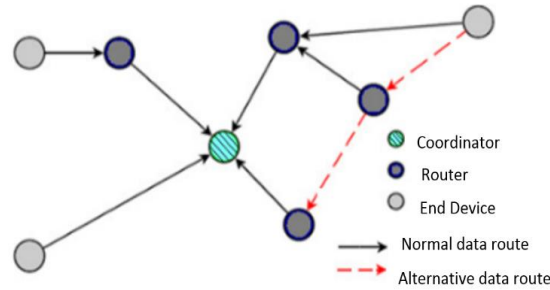

Figure 2 General ZigBee Device Network.



Figure 3 API data packet.

The API-specific Structure contains all the information related to analog readings, digital readings and the device that sends the information to the coordinator.

Figure 4 shows the block diagram of how the network is implemented for the acquisition system. It can be seen that several antennas can be spread through all the building and connected at the same time to the smart central unit. The information of different sensors can be associated with each signal monitoring card (up to four analog sensors and three digital sensors due to XBee physical constraints) and it can follow different routes to the central unit. Since the range of XBee is limited, the information can pass directly to the central unit or be resent through a ZigBee Router. Furthermore, it is possible to connect the smart central unit to a PC to interchange relevant information collected by this and add new antennas to the grid with minimal changes according to personal necessities.

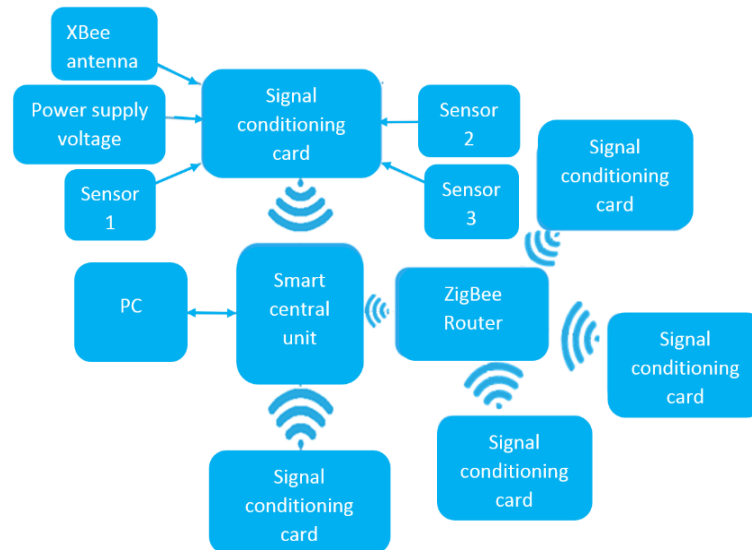

Figure 4 Network to be implemented.

To prove the functionality of the system, it was installed in a specific case, where an acquisition signal board was mounted in a classroom, and less than 30 m away (range of XBee devices), the signal monitoring board was placed.

The developed system consists of signal monitoring module (figure 5):

- a) Light sensor.
- b) Smoke gas sensor.
- c) Presence sensor.
- d) Glass breakage sensor.
- e) Temperature sensor.
- f) Signal conditioning module.

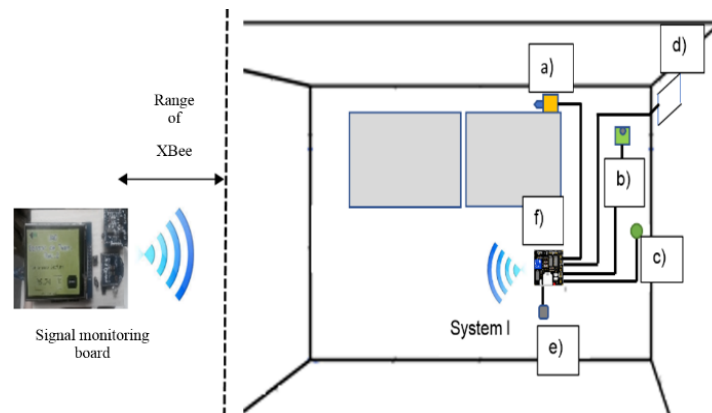

Figure 5 Schematic diagram of the installation of the proposed system in an enclosure.

To send the information, a signal conditioning module is needed because most of the sensors have a non-standardized voltage signal in the output that must be compatible with the XBee devices. Also, the conditioning module must work as the power source for the sensors. Each analog sensor used requires to adjust its voltage from 5 V to 1.2 V as maximum output voltage, so the circuit shown in figure 6 is used for this purpose, the same circuit is applied for each of the four analog ports included in every XBee antenna. It is used two voltage followers because some sensors are resistive-type sensors, so if a voltage follower is not included between the input and the resistive voltage divider there will be an extra resistive array which will cause the voltage to divide, the same is true for the voltage after the resistive voltage divider.

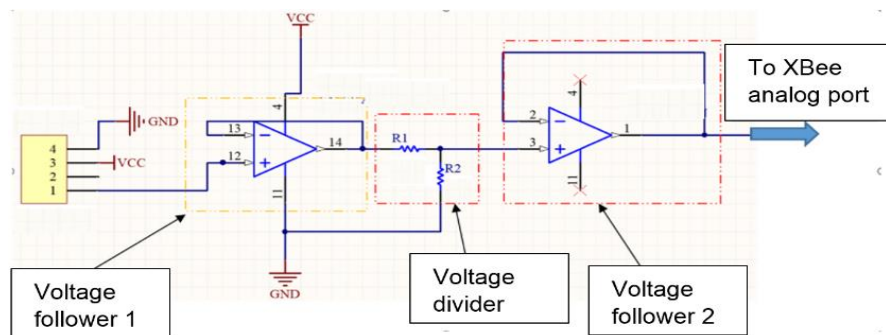

Figure 6 Signal conditioning for every analog sensor.

The signal conditioning module includes the following items; a socket for the XBee antenna, a LED that indicates a good operation of the XBee module, a relay to operate high power devices such as motors, lamps, etc., and two pins to implement a communication with an extra microcontroller.

Once the hardware modules that fulfill the function to send the data are designed, the information of all the physical variables measured in the building is collected in one coordinator device and they must be shown in a simple and clear way to the final user, so with the help of a touchscreen and an Arduino Due board the system shows real-time readings, and creates plots from data saved in a Micro SD following the flowchart presented in figure 7. First, when the reset button is pressed, the program starts and initialize the components required to accomplish



the functions described before which are: one digital real-time clock, one Micro SD flash memory, and one touchscreen module. Once the components are initialized, network status data must be obtained from Micro SD to show the correct parameters. After this point, the data from all the nodes must be acquired serially by the XBee coordinator, if there is no data, the touch sensor coordinates must be obtained to update the menu according to the command requested by the user. If the user doesn't touch the screen and the last request was to show real time data, the screen must show the readings specified. To end a loop cycle, the data obtained from the network must be recorded to get it ready in any time requested.

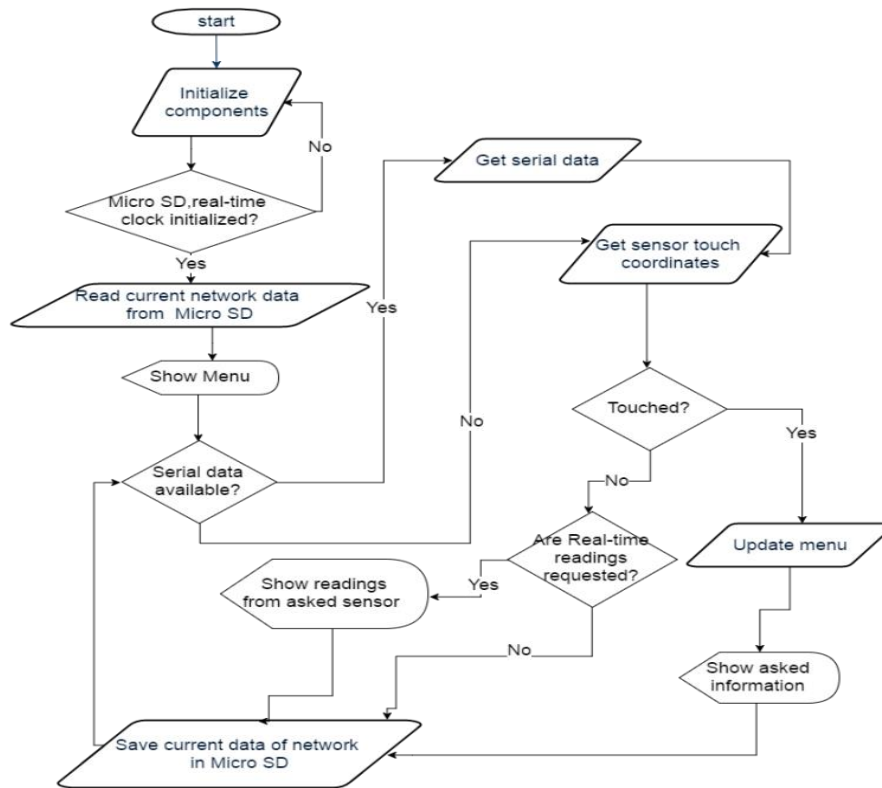

Figure 7 Flowchart to establish a user-machine interface.

### 3. Results

The results are shown in the following figures. The experimental tests of the system were run over two months in a classroom of the Universidad Autonoma de Queretaro. The readings obtained from the temperature sensor with the system proposed were compared with a thermocouple multimeter.

As seen in figure 8, a formal signal conditioning board was designed and fabricated; such board can send data from four analog sensors and three digital sensors to the coordinator XBee. The board is capable of receiving commands from the coordinator and execute an action to drive power elements or pass information to another microcontroller. One or more of these modules can be installed in one room according to space requirements avoiding complex wired connections.



Figure 8 Signal conditioning board.

A signal monitoring board, presented in figure 9, was also designed and fabricated with the purpose of working as a human-machine interface. This board includes a touchscreen which makes a robust and flexible system since a PC is not needed to monitor the signals.



Figure 9 Signal monitoring board.

Furthermore, to demonstrate the functionality of the system, this was installed in an enclosure as shown in figure 10, where all the sensors can be seen installed and connected to one signal conditioning card.

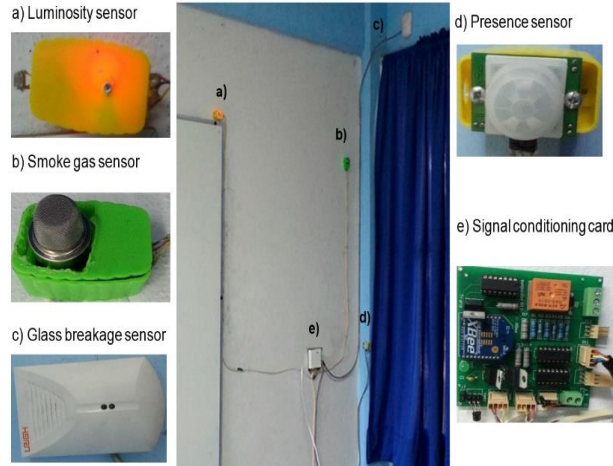

Figure 10 Proposed system installed in a classroom.

The main functional screens of the touchscreen included in the system are shown below in figure11:

- a) screen menu that indicates the place where the signal monitoring board is installed.
- b) Displays from what sensor the user wants to see the readings.
- c) Screen of the real-time readings
- d) Illustrates an example of the plots that the system is capable of making.

It is demonstrated that the user can observe and access to the state of all the building through real-time readings of the sensors with few touches on the screen. It is also, possible to create plots of all the variables measured and saved in the Micro SD memory flash.

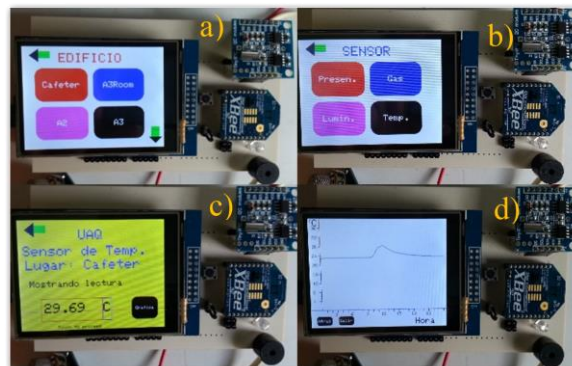

Figure 11 Main functional screens of the system proposed.

To make a more flexible system in the number of antennas that can be spread into a building, a software wizard was developed to indicate to the signal monitoring board that a new antenna is required to add to the current network with a PC via USB port. Also, the software can trace data collected and saved for analysis indicating the current location and the serial number printed in each antenna connected. The software was developed in Visual Studio c# 2013 in a PC laptop of 1.8 GHz with operative system Windows 8. To accomplish its functionality, the program is divided into three main functions: making graphics, sending information and receiving information from Arduino Due microcontroller. When the user wants to add a new antenna to the actual network it is necessary to fill some information asked by the program. Also, the program shows comments to specify the information required in case of mistakes, if the information is correct, then it is sent to the microcontroller via USB port.

#### **4. Discussion**

To probe the accuracy and the precision of signal acquisition system 100 samples were taken (one sample per minute) of the temperature sensor and a digital multimeter fluke 177 with a thermocouple to compare the samples. The results obtained are the following:

- The RMS error between the used systems provides an average value of 0.301186129 °C.
- The Pearson correlation coefficient gave a 98.819% of relation between the thermocouple Fluke and the temperature sensor used with a relative error of 1.0594339%.

In general, an error below 3% is already considered as an acceptable value for a measurement system and therefore as the proposed system has an error close to 1% it can be concluded that it presents a high accuracy with respect to a commercial system.

The system can be implemented in different fields that require wireless signal acquisition since it has high accuracy acquiring signals from sensors. As it includes

a microcontroller, the information acquired can be processed to activate power modules and expand its functionality.

Since the system uses ZigBee antennas, some tests were effectuated to verify their range, placing the monitoring board at 30 m from one signal conditioning board (with no routers in between) without obstacles (outdoor range), one wall and two walls as obstacles verifying that with one wall the signal presents no problems of data lost, but when two walls were located between transmitter and emitter, the signal was lost randomly with no warranty.

## **5. Conclusions**

In this work, a domotic system that uses ZigBee for the acquisition of data from sensors in a wireless way was developed having a better range than Bluetooth and less power consumption than Wi-fi. From the previous remarks, it is verified that the proposed system presents results comparable to those of commercial purpose but with a greater flexibility and lower cost.

The use of a ZigBee wireless system for the monitoring of signals from electrical sensors offers multiple advantages over a wired system:

- Ease of installation, as the final system does not require complex connections or special wiring.
- Flexibility to place the central module/display anywhere in the building, instead of being fixed.
- Possibility of integration as a node belonging to a network of sensors connected to a central home automation system.
- Possibility of acquiring and monitoring additional or different signals to the ones already used (temperature, luminosity, gas, and presence) and transmit all data at the same time to the network coordinator using the same ZigBee radio transmitter.

As a disadvantage of the module, some data packets are lost when some obstacles are placed between the monitoring board and the signal conditioning board losing reliability when all samples are required to arrive. This drawback can

be overcome by using a router in order to amplify the scope of the signal emitted by the ZigBee antenna.

The system created will be installed in a building of the Universidad Autónoma de Queretaro, CATAS (Academic Center of Advanced and Sustainable Technologies) to collect all the information of the state of the building and concentrate them in one central unit, with the facility to move it from place to place if needed and add new antennas to the current network.

### **Acknowledgment**

This work was supported by FOMIX QRO-2014-C03-250269 and CONACYT scholarship 652815.

## **6. Bibliography and References**

- [1] Brito J., Gomes T., Miranda J., Monteiro J. L., Cabral J., An intelligent home automation control system based on a novel heat pump and wireless sensor networks, 978-1-4799-2399-5/14 IEEE, 2014.
- [2] Bromley M. and Webb G., Trends in smart home systems, connectivity, and services, 2003.
- [3] Cofré J. P., Moraga G., Rusu C., Mercado I., Inostroza R., Jiménez J., Developing a touchscreen-based domotic tool for users with motor disabilities, 978-0-7695-4654-4/12 IEEE, 2012.
- [4] Dobrescu L., Domotic embedded system, 9788-1-4799-5479-7/14 IEEE., 2014.
- [5] Eurico L., Luis V., Fernão P., and Filipe D., A zigbee wireless domotic system with bluetooth interface, 9788-1-4799-4032-5/14 IEEE, 2014.
- [6] Khusvinder G., Shuang-Hua Y., Fang Y., and Xin L., A zigbee-based home automation system, IEEE Transactions on Consumer Electronics, Vol. 55, No. 2, May 2009.
- [7] Maxim O., Home automation with zigbee, Computer Science, 5174, 2008.
- [8] O'Driscoll G., The essential guide to home networking technologies, Prentice Hall, 2000.

- [9] Sánchez D., Diseño de una casa inteligente basado en la tecnología jini. Undergraduate dissertation, Mexico, 2004.
- [10] Semanur K., İbrahim S., Alper Ş., A low cost smart security and home automation system employing an embedded server and a wireless sensor network, International Conference on Consumer Electronics-Berlin, 2016.
- [11] Shuaib K., Boulmalf M., Sallabi F., and Lakas A., Co-existence of zigbee and wlan a performance study, IFIP International Conference on Wireless and Optical Communications Networks, pp. 5, 2006.
- [12] Stavropoulos T.G., Tsioliaridou A., Koutitas G., Vrakas D., and Vlahavas I. System architecture for a smart university building, Diamantaras, K., Duch, W., Iliadis, L.S. (eds.) ICANN 2010, Part III. LNCS, vol. 6354, pp. 477-482. Springer, Heidelberg 2010.
- [13] Vikram P. and Nayyar A., Real time smart home automation based on pic microcontroller, Bluetooth, and Android Technology. 978-9-3805-4421-2/16 IEEE, 2016.